

# Tool Suspension Systems

For steel and plastic strapping

**SIGNODE®**

## Overhead tool balancers

Tool balancers are the easiest and most efficient way to suspend strapping tools from a fixed ceiling bracket, monorail, jib or bridge crane.



**BFL-9**  
Part No. 423283\*  
6-9 lbs. (2.7-4.1 kg),  
6.6 ft. (2 m) cable travel



**EB2500R**  
Part No. 485001\*  
18-25 lbs. (8.2-11.4 kg),  
6.6 ft. (2 m) cable travel



**10FLR**  
Part No. 485010  
4-10 lbs. (1.8-4.5 kg),  
8 ft. (2.4 m) cable travel

**15FLR**  
Part No. 485011  
8-15 lbs. (3.6-6.8 kg),  
8 ft. (2.4 m) cable travel

**BFL-13**  
Part No. 306809\*  
9-13 lbs. (4.1-5.9 kg),  
6.6 ft. (2 m) cable travel

**EB3500R**  
Part No. 485002  
25-35 lbs. (11.3-15.9 kg),  
6.6 ft. (2 m) cable travel

**BFL-18**  
Part No. 423278\*  
13-18 lbs. (5.9-8.2 kg),  
6.6 ft. (2 m) cable travel

**EB4500R**  
Part No. 485003  
35-45 lbs. (15.9-20.5 kg),  
6.6 ft. (2 m) cable travel

\* Ratchet lock halts cable at desired position, prevents creep. The lock can be released by a tug and can also be disengaged.

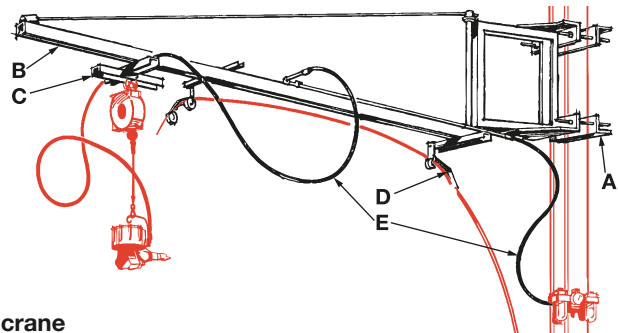

### Jib crane

Signode's JN-15, Part No. 084165, is a 15 ft. (4.6 m) jib crane used to suspend pneumatic combination tools overhead. It handles steel strapping in widths up to 1-1/4" (31.8 mm).

- A. Post mounting bracket
- B. Enclosed trolley track
- C. Tool carrier assembly
- D. Strap guide rollers
- E. Air line components

# Power Strap Feeder (PSF-2)

For plastic and steel strapping

The PSF-2 power strap feeder is designed to improve virtually any manual packaging operation regardless of package size, strapping material, pallet type or packaging line configuration.

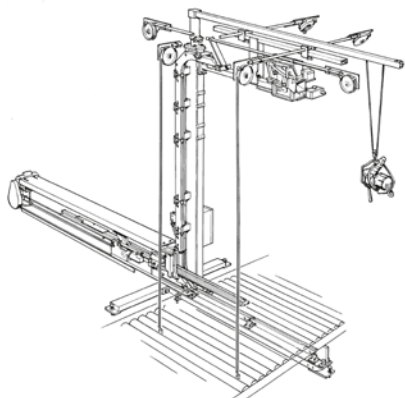

The modular design can be customized to accommodate your packaging operation.

Standard features: automatic strap feed shutoff, automatic seal feed bend-over device.

Options: chute extensions, casters, pallet void feeding attachments, strap grippers, strap directors and more.

### Efficiency

Automatic strap feeding greatly improves production speed and helps eliminate bottlenecks.

### Economy

The PSF-2 requires only one operator (two or more are required for manual strap feeding), which can significantly reduce operating costs. Your labor cost savings, coupled with increased production, elimination of bottlenecks and the PSF-2's low cost, gives you a relatively quick return on investment.

### Specifications

- Maximum package size:** 76"H (1930mm), 48" (1219mm) front to back
- Steel strapping:** 3/8" x .017" to 3/4" x .031" (9.5mm x 0.43mm to 19mm x 0.79mm)
- Plastic strapping:** Tenax® 1716, 1718, 1816, 1818, 1822, 2030, 2040  
Conrax® HD 723, HD 729, 816, 818
- Dispenser:** DF-23, DF-1-12D
- Tool suspension:** Overhead jib suspension with cable
- Motor:** 1/4 hp (.1864 KW), 1140 RPM, 115V, single phase, 60Hz